

# Zy+us Cad+ila



## Case Study

Zydus Cadila is headquartered in Ahmedabad, India, and ranks 4th in the Indian pharmaceutical industry. The group has manufacturing sites and research facilities spread across five states of Gujarat, Maharashtra, Goa, Himachal Pradesh and Sikkim in India and in the US and Brazil. Zydus' global business has a strong presence in the regulated markets of the US, Europe (France and Spain) and in the high profile markets of Latin America and South Africa. It is also present in a big way in 25 other emerging markets worldwide.

### Requirements

Zydus has manufacturing plants across the country like Ahmedabad, Goa, Ankleshwar, Dabhasa, Baddi, Sikkim & Burma. But Ahmedabad poses maximum manufacturing infrastructure of Zydus Cadilla and consequently it is also of paramount importance. As such zydus cadilla was coming up with a new project of a Manufacturing facility in Ahmedabad SEZ. Zydus had a history of working with a fixed partner for its Clean Room requirements of which we had knowledge still we made an effort to wipe this history. In this came our trusted partner Impacton who aligned with us in taking up this challenge. Impacton had resilience and composure while we were weaponized with our confidence and trust in our products.

## Solution offer by Enviro Technologies

Zydus Cadila known for its NCEs to vaccines, biosimilar's and niche technologies, a group which explores different ideas and concepts, innovating constantly. As such It was of paramount importance to provide excellent products and service in terms of installation, site commissioning and after sales support.

We offered our ETN-TFT Series (Coloured Display's - T + RH & only DP) to the new Ahmedabad SEZ plant. It was complied with third party BMS/EMS software. The proficiency and effective domain knowledge of clean room vertical impressed the Zydus team and established us a pathway for longstanding bond.

User feedback was overwhelming, our partners enthusiasm and energy along with our quality systems helped us get us continuous orders till date to which we are still catering and nurturing. The benefits of the system like durability & robustness impressed everyone with beautiful stainless front it also added to the aesthetics a bit.

### Salient Features were

1. Fast as well as precise, as they have a large pressure range
2. Small increments of pressure change can be detected
3. Efficient reading memory with 3.5" TFT display
4. International quality and standards taking in cognizance international measurements like Pascal & mmWc
5. Undeterred towards over-pressure or constant pressure pulsation

## Highlights of the Project

Total Number of DPMS – 1050

Plants – Mumbai & Kandla

# Connection Diagram

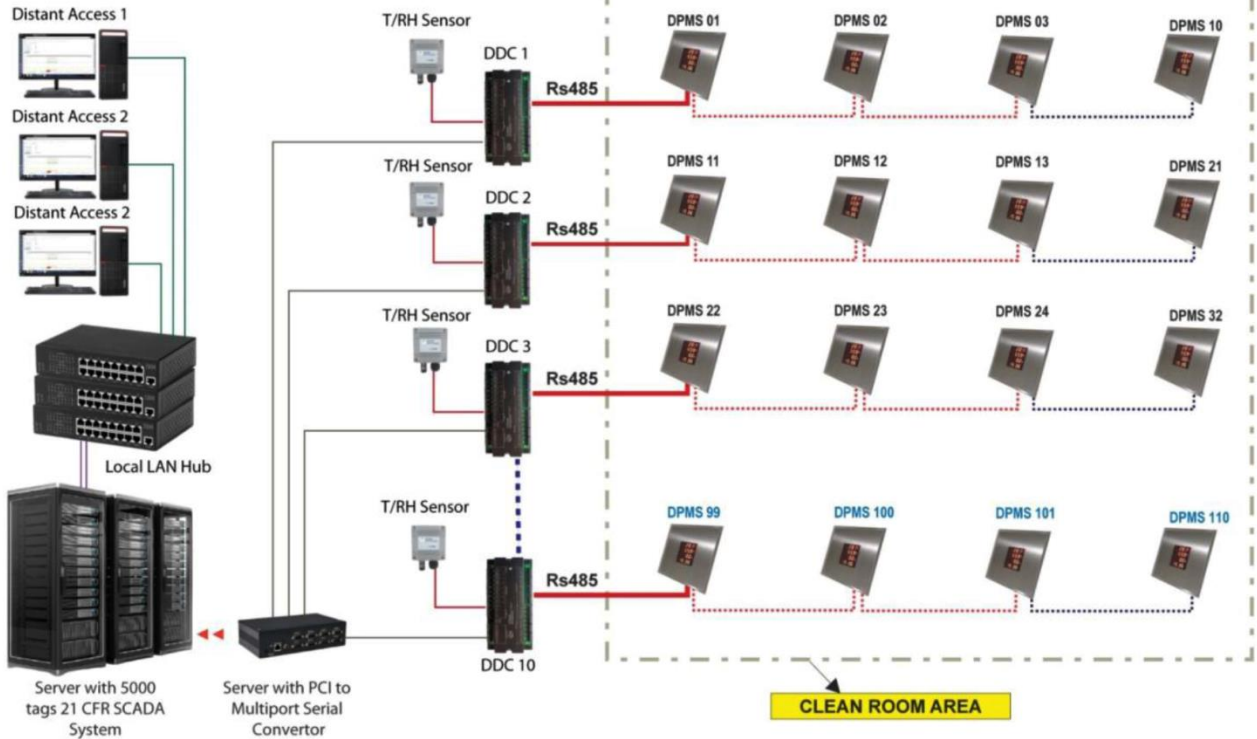

## ENVIRO TECHNOLOGIES

### Head Office:

R&D, Training & Customer Support Centre,  
Units 254, 2nd Floor, Building No D-7,  
Bhumi World, Pimplas, Opposite Tata Housing – Amantra, Bhiwandi,  
Thane – 421302. Maharashtra. INDIA.

Tel: +91-02522-661513

[www.enviro-technologies.com](http://www.enviro-technologies.com)